



512K x 36 / 1M x 18 Pipelined SRAM

Features

- **Fast clock speed: 200,167, 150, 133 MHz**
- **Provide high-performance 3-1-1-1 access rate**
- **Fast OE access times: 3.0, 3.4, 3.8, 4.2 ns**
- **Optimal for depth expansion**
- **2.5V ±5% power supply**
- **Common data inputs and data outputs**
- **Byte Write Enable and Global Write control**
- **Chip enable for address pipeline**
- **Address, data, and control registers**
- **Internally self-timed Write cycle**
- **Burst control pins (interleaved or linear burst sequence)**
- **Automatic power-down available using ZZ mode or CE deselect**
- **High-density, high-speed packages**
- **JTAG boundary scan for BGA packaging version**

Functional Description

The Cypress Synchronous Burst SRAM family employs high-speed, low-power CMOS designs using advanced single-layer polysilicon, triple-layer metal technology. Each memory cell consists of six transistors.

The CY7C1382BV25 and CY7C1380BV25 SRAMs integrate 1,048,576 x 18 and 524,288 x 36 SRAM cells with advanced synchronous peripheral circuitry and a two-bit counter for internal burst operation. All synchronous inputs are gated by

registers controlled by a positive-edge-triggered clock input (CLK). The synchronous inputs include all addresses, all data inputs, address-pipelining Chip Enable (CE), burst control inputs (ADSC, ADSP, and ADV), Write Enables (BWA, BWb, BWc, BWd and BWE), and Global Write (GW).

Asynchronous inputs include the output enable (\overline{OE}) and burst mode control (MODE). The data (DQ_{a,b,c,d}) and the data parity (DQP_{a,b,c,d}) outputs, enabled by OE, are also asynchronous.

DQ_{a,b,c,d} and DP_{a,b,c,d} apply to CY7C1380BV25 and DQ_{a,b} and DP_{a,b} apply to CY7C1382BV25. a, b, c, d each are eight bits wide in the case of DQ and one bit wide in the case of DP.

Addresses and chip enables are registered with either address status processor (ADSP) or address status controller (ADSC) input pins. Subsequent burst addresses can be internally generated as controlled by the burst advance pin (ADV).

Address, data inputs, and write controls are registered on-chip to initiate self-timed WRITE cycle. WRITE cycles can be one to four bytes wide as controlled by the write control inputs. Individual byte write allows individual byte to be written. BWA controls DQa and DPa. BWb controls DQb and DPb. BWc controls DQc and DPc. BWd controls DQd-DQd and DPd. BWA, BWb, BWc, and BWd can be active only with BWE being LOW. GW being LOW causes all bytes to be written. WRITE pass-through capability allows written data available at the output for the immediately next Read cycle. This device also incorporates pipelined enable circuit for easy depth expansion without penalizing system performance.

All inputs and outputs of the CY7C1380BV25 and the CY7C1382BV25 are JEDEC-standard JESD8-5-compatible.

Selection Guide

		200 MHz	167 MHz	150 MHz	133 MHz	Unit
Maximum Access Time		3.0	3.4	3.8	4.2	ns
Maximum Operating Current	Commercial	280	230	190	160	mA
Maximum CMOS Standby Current		30	30	30	30	mA

Logic Block Diagram
512K x 36

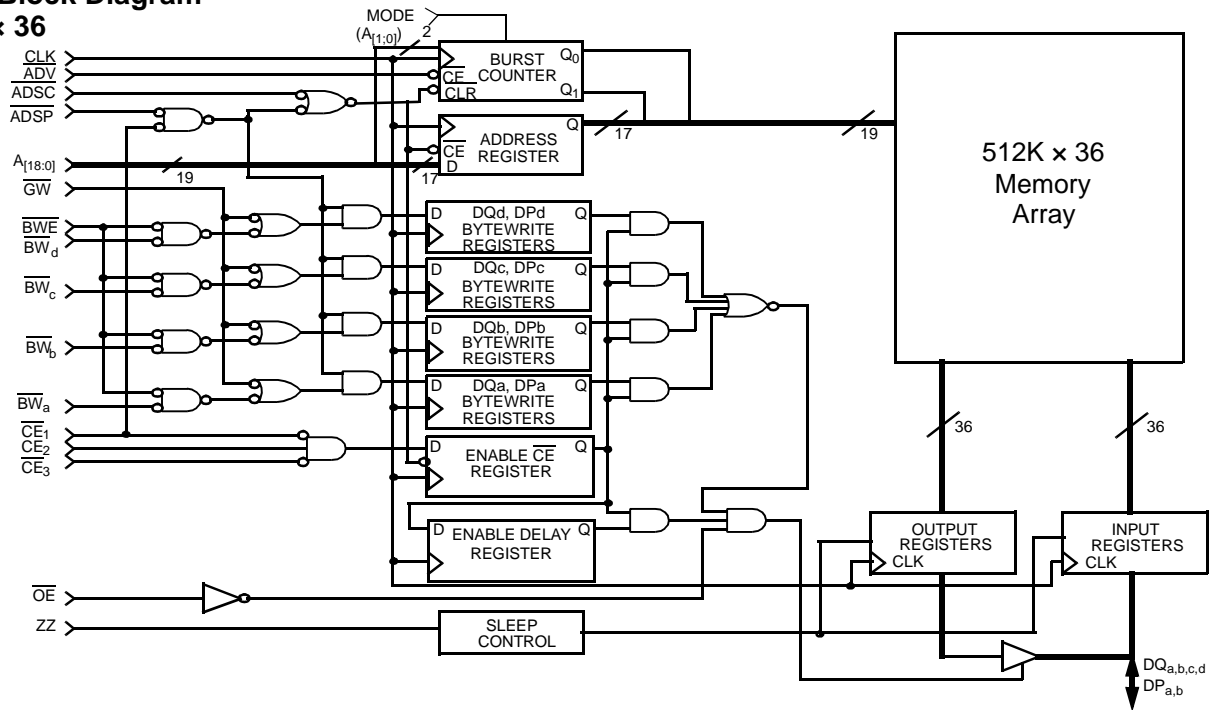

Logic Block Diagram
1M x 18

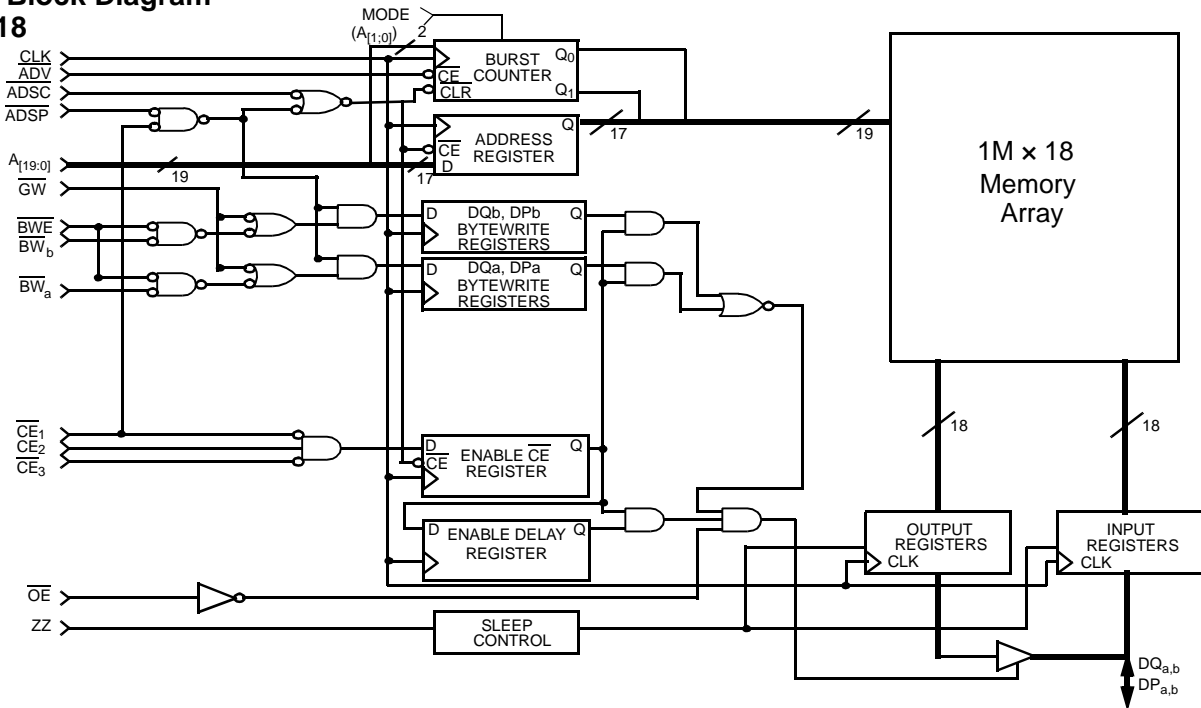

Pin Configurations

100-pin TQFP
 Top View

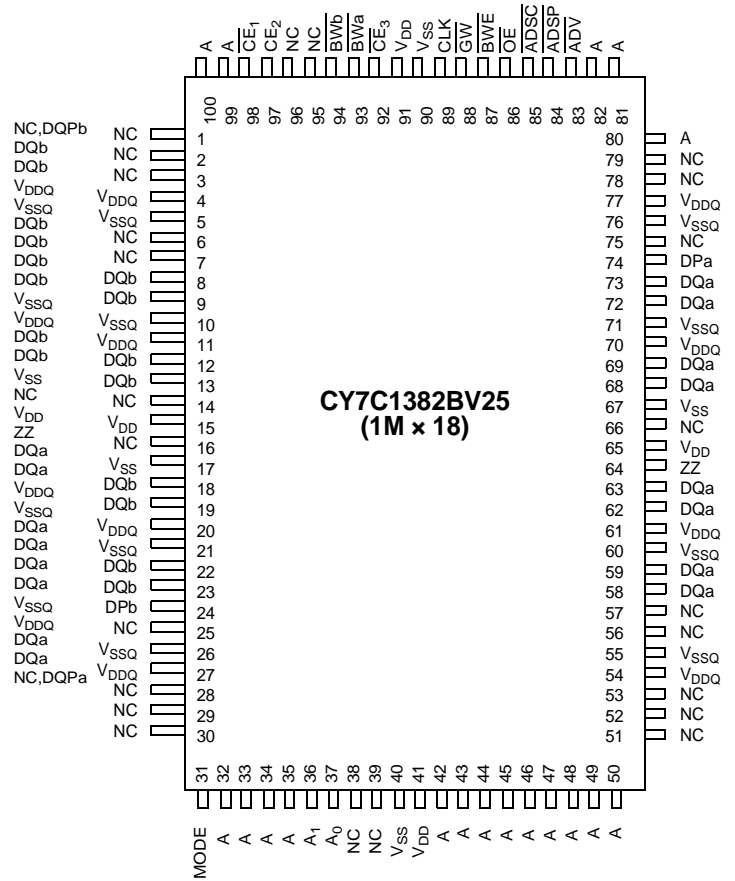
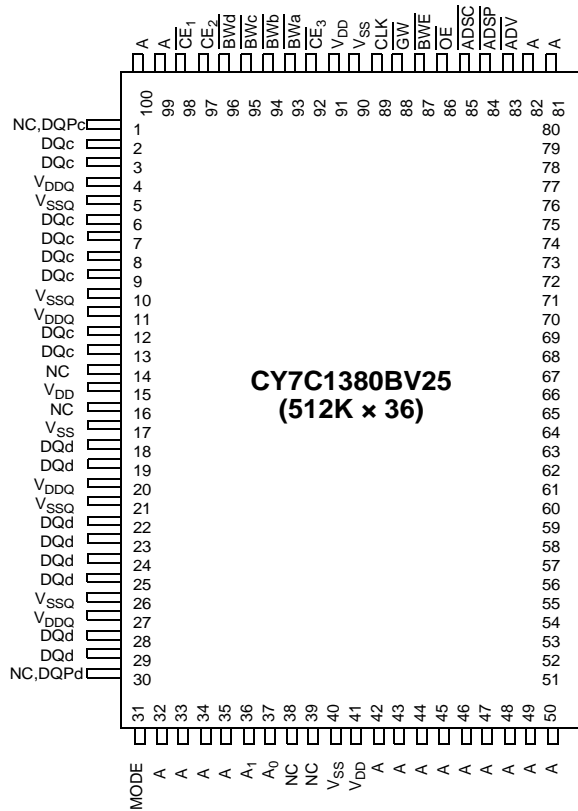



Pin Configurations (continued)

119-ball BGA

CY7C1380BV25 (512K x 36)

	1	2	3	4	5	6	7
A	V _{DDQ}	A	A	$\overline{\text{ADSP}}$	A	A	V _{DDQ}
B	NC	A	A	$\overline{\text{ADSC}}$	A	A	NC
C	NC	A	A	V _{DD}	A	A	NC
D	DQc	DQPc	V _{SS}	NC	V _{SS}	DQPb	DQb
E	DQc	DQc	V _{SS}	$\overline{\text{CE}}_1$	V _{SS}	DQb	DQb
F	V _{DDQ}	DQc	V _{SS}	$\overline{\text{OE}}$	V _{SS}	DQb	V _{DDQ}
G	DQc	DQc	$\overline{\text{BWC}}$	$\overline{\text{ADV}}$	$\overline{\text{BWb}}$	DQb	DQb
H	DQc	DQc	V _{SS}	$\overline{\text{GW}}$	V _{SS}	DQb	DQb
J	V _{DDQ}	V _{DD}	NC	V _{DD}	NC	V _{DD}	V _{DDQ}
K	DQd	DQd	V _{SS}	CLK	V _{SS}	DQa	DQa
L	DQd	DQd	$\overline{\text{BWd}}$	NC	$\overline{\text{BWa}}$	DQa	DQa
M	V _{DDQ}	DQd	V _{SS}	$\overline{\text{BWE}}$	V _{SS}	DQa	V _{DDQ}
N	DQd	DQd	V _{SS}	A1	V _{SS}	DQa	DQa
P	DQd	DQPd	V _{SS}	A0	V _{SS}	DQPa	DQa
R	NC	A	MODE	V _{DD}	NC	A	NC
T	NC	64M	A	A	A	32M	ZZ
U	V _{DDQ}	TMS	TDI	TCK	TDO	NC	V _{DDQ}

CY7C1382BV25 (1M x 18)

	1	2	3	4	5	6	7
A	V _{DDQ}	A	A	$\overline{\text{ADSP}}$	A	A	V _{DDQ}
B	NC	A	A	$\overline{\text{ADSC}}$	A	A	NC
C	NC	A	A	V _{DD}	A	A	NC
D	DQb	NC	V _{SS}	NC	V _{SS}	DQPa	NC
E	NC	DQb	V _{SS}	$\overline{\text{CE}}_1$	V _{SS}	NC	DQa
F	V _{DDQ}	NC	V _{SS}	$\overline{\text{OE}}$	V _{SS}	DQa	V _{DDQ}
G	NC	DQb	$\overline{\text{BWb}}$	$\overline{\text{ADV}}$	V _{SS}	NC	DQa
H	DQb	NC	V _{SS}	$\overline{\text{GW}}$	V _{SS}	DQa	NC
J	V _{DDQ}	V _{DD}	NC	V _{DD}	NC	V _{DD}	V _{DDQ}
K	NC	DQb	V _{SS}	CLK	V _{SS}	NC	DQa
L	DQb	NC	V _{SS}	NC	$\overline{\text{BWa}}$	DQa	NC
M	V _{DDQ}	DQb	V _{SS}	$\overline{\text{BWE}}$	V _{SS}	NC	V _{DDQ}
N	DQb	NC	V _{SS}	A1	V _{SS}	DQa	NC
P	NC	DQPb	V _{SS}	A0	V _{SS}	NC	DQa
R	NC	A	MODE	V _{DD}	NC	A	NC
T	64M	A	A	32M	A	A	ZZ
U	V _{DDQ}	TMS	TDI	TCK	TDO	NC	V _{DDQ}

Pin Configurations (continued)

165-ball Bump FBGA
CY7C1380BV25 (512K × 36)–11 × 15 FBGA

	1	2	3	4	5	6	7	8	9	10	11
A	NC	A	\overline{CE}_1	\overline{BWc}	\overline{BWb}	\overline{CE}_3	\overline{BWE}	\overline{ADSC}	\overline{ADV}	A	NC
B	NC	A	CE_2	\overline{BWd}	\overline{BWa}	CLK	\overline{GW}	\overline{OE}	\overline{ADSP}	A	128M
C	DPc	NC	V_{DDQ}	V_{SS}	V_{SS}	V_{SS}	V_{SS}	V_{SS}	V_{DDQ}	NC	DPb
D	DQc	DQc	V_{DDQ}	V_{DD}	V_{SS}	V_{SS}	V_{SS}	V_{DD}	V_{DDQ}	DQb	DQb
E	DQc	DQc	V_{DDQ}	V_{DD}	V_{SS}	V_{SS}	V_{SS}	V_{DD}	V_{DDQ}	DQb	DQb
F	DQc	DQc	V_{DDQ}	V_{DD}	V_{SS}	V_{SS}	V_{SS}	V_{DD}	V_{DDQ}	DQb	DQb
G	DQc	DQc	V_{DDQ}	V_{DD}	V_{SS}	V_{SS}	V_{SS}	V_{DD}	V_{DDQ}	DQb	DQb
H	NC	V_{SS}	NC	V_{DD}	V_{SS}	V_{SS}	V_{SS}	V_{DD}	NC	NC	ZZ
J	DQd	DQd	V_{DDQ}	V_{DD}	V_{SS}	V_{SS}	V_{SS}	V_{DD}	V_{DDQ}	DQa	DQa
K	DQd	DQd	V_{DDQ}	V_{DD}	V_{SS}	V_{SS}	V_{SS}	V_{DD}	V_{DDQ}	DQa	DQa
L	DQd	DQd	V_{DDQ}	V_{DD}	V_{SS}	V_{SS}	V_{SS}	V_{DD}	V_{DDQ}	DQa	DQa
M	DQd	DQd	V_{DDQ}	V_{DD}	V_{SS}	V_{SS}	V_{SS}	V_{DD}	V_{DDQ}	DQa	DQa
N	DPd	NC	V_{DDQ}	V_{SS}	NC	A	V_{SS}	V_{SS}	V_{DDQ}	NC	DPa
P	NC	64M	A	A	TDI	A1	TDO	A	A	A	A
R	MODE	32M	A	A	TMS	A0	TCK	A	A	A	A

CY7C1382BV25 (1M × 18)–11 × 15 FBGA

	1	2	3	4	5	6	7	8	9	10	11
A	NC	A	\overline{CE}_1	\overline{BWb}	NC	\overline{CE}_3	\overline{BWE}	\overline{ADSC}	\overline{ADV}	A	A
B	NC	A	CE_2	NC	\overline{BWa}	CLK	\overline{GW}	\overline{OE}	\overline{ADSP}	A	128M
C	NC	NC	V_{DDQ}	V_{SS}	V_{SS}	V_{SS}	V_{SS}	V_{SS}	V_{DDQ}	NC	DPa
D	NC	DQb	V_{DDQ}	V_{DD}	V_{SS}	V_{SS}	V_{SS}	V_{DD}	V_{DDQ}	NC	DQa
E	NC	DQb	V_{DDQ}	V_{DD}	V_{SS}	V_{SS}	V_{SS}	V_{DD}	V_{DDQ}	NC	DQa
F	NC	DQb	V_{DDQ}	V_{DD}	V_{SS}	V_{SS}	V_{SS}	V_{DD}	V_{DDQ}	NC	DQa
G	NC	DQb	V_{DDQ}	V_{DD}	V_{SS}	V_{SS}	V_{SS}	V_{DD}	V_{DDQ}	NC	DQa
H	NC	V_{SS}	NC	V_{DD}	V_{SS}	V_{SS}	V_{SS}	V_{DD}	NC	NC	ZZ
J	DQb	NC	V_{DDQ}	V_{DD}	V_{SS}	V_{SS}	V_{SS}	V_{DD}	V_{DDQ}	DQa	NC
K	DQb	NC	V_{DDQ}	V_{DD}	V_{SS}	V_{SS}	V_{SS}	V_{DD}	V_{DDQ}	DQa	NC
L	DQb	NC	V_{DDQ}	V_{DD}	V_{SS}	V_{SS}	V_{SS}	V_{DD}	V_{DDQ}	DQa	NC
M	DQb	NC	V_{DDQ}	V_{DD}	V_{SS}	V_{SS}	V_{SS}	V_{DD}	V_{DDQ}	DQa	NC
N	DPb	NC	V_{DDQ}	V_{SS}	NC	A	V_{SS}	V_{SS}	V_{DDQ}	NC	NC
P	NC	64M	A	A	TDI	A1	TDO	A	A	A	A
R	MODE	32M	A	A	TMS	A0	TCK	A	A	A	A

Pin Definitions

Pin Name	I/O	Pin Description
A0 A1 A	Input-Synchronous	Address <u>Inputs used to select one of the address locations</u> . Sampled at the rising edge of the CLK if ADSP or ADSC is active LOW, and \overline{CE}_1 , \overline{CE}_2 , and \overline{CE}_3 are sampled active. $A_{[1:0]}$ feed the two-bit counter.
\overline{BWA} \overline{BWB} \overline{BWC} \overline{BWD}	Input-Synchronous	Byte Write Select Inputs, active LOW. Qualified with \overline{BWE} to conduct byte writes to the SRAM. Sampled on the rising edge of CLK.
\overline{GW}	Input-Synchronous	Global Write Enable Input, active LOW. When asserted LOW on the rising edge of CLK, a global write is conducted (ALL bytes are written, regardless of the values on $\overline{BW}_{a,b,c,d}$ and \overline{BWE}).
\overline{BWE}	Input-Synchronous	Byte Write Enable Input, active LOW. Sampled on the rising edge of CLK. This signal must be asserted LOW to conduct a byte write.
CLK	Input-Clock	Clock Input. Used to capture all synchronous inputs to the device. Also used to increment the burst counter when ADV is asserted LOW, during a burst operation.
\overline{CE}_1	Input-Synchronous	Chip Enable 1 Input, active LOW. Sampled on the rising edge of CLK. Used in conjunction with \overline{CE}_2 and \overline{CE}_3 to select/deselect the device. ADSP is ignored if \overline{CE}_1 is HIGH.
\overline{CE}_2	Input-Synchronous	Chip Enable 2 Input, active HIGH. Sampled on the rising edge of CLK. Used in conjunction with \overline{CE}_1 and \overline{CE}_3 to select/deselect the device (TQFP only).
\overline{CE}_3	Input-Synchronous	Chip Enable 3 Input, active LOW. Sampled on the rising edge of CLK. Used in conjunction with \overline{CE}_1 and \overline{CE}_2 to select/deselect the device (TQFP only).
OE	Input-Asynchronous	Output Enable, asynchronous input, active LOW. Controls the direction of the I/O pins. When LOW, the I/O pins behave as outputs. When deasserted HIGH, I/O pins are three-stated, and act as input data pins. \overline{OE} is masked during the first clock of a read cycle when emerging from a deselected state.
ADV	Input-Synchronous	Advance Input signal, sampled on the rising edge of CLK. When asserted, it automatically increments the address in a burst cycle.
ADSP	Input-Synchronous	Address Strobe from Processor, sampled on the rising edge of CLK. When asserted LOW, A is captured in the address registers. $A_{[1:0]}$ are also loaded into the burst counter. When ADSP and ADSC are both asserted, only ADSP is recognized. ADSP is ignored when \overline{CE}_1 is deasserted HIGH.
ADSC	Input-Synchronous	Address Strobe from Controller, sampled on the rising edge of CLK. When asserted LOW, $A_{[1:0]}$ is captured in the address registers. $A_{[1:0]}$ are also loaded into the burst counter. When ADSP and ADSC are both asserted, only ADSP is recognized.
MODE	Input-Pin	Selects Burst Order. When tied to GND selects linear burst sequence. When tied to V_{DDQ} or left floating selects interleaved burst sequence. This is a strap pin and should remain static during device operation.
ZZ	Input-Asynchronous	ZZ “sleep” Input. This active HIGH input places the device in a non-time critical “sleep” condition with data integrity preserved.
DQa, DPa DQb, DPb DQc, DPc DQd, DPd	I/O-Synchronous	Bidirectional Data I/O lines. As inputs, they feed into an on-chip data register that is triggered by the rising edge of CLK. As outputs, they deliver the data contained in the memory location specified by $A_{[1:0]}$ during the previous clock rise of the read cycle. The direction of the pins is controlled by \overline{OE} . When \overline{OE} is asserted LOW, the pins behave as outputs. When HIGH, DQx and DPx are placed in a three-state condition. DQ a,b,c and d are eight bits wide and the DP a,b,c and d are one bit wide.
TDO	JTAG serial output Synchronous	Serial data-out to the JTAG circuit. Delivers data on the negative edge of TCK (BGA only).
TDI	JTAG serial input Synchronous	Serial data-In to the JTAG circuit. Sampled on the rising edge of TCK (BGA only).
TMS	Test Mode Select Synchronous	This pin controls the Test Access Port state machine. Sampled on the rising edge of TCK (BGA only).

Pin Definitions

Pin Name	I/O	Pin Description
TCK	JTAG serial clock	Serial clock to the JTAG circuit (BGA only).
V _{DD}	Power Supply	Power supply inputs to the core of the device. Should be connected to a 2.5V \pm 5% power supply.
V _{SS}	Ground	Ground for the core of the device. Should be connected to ground of the system.
V _{DDQ}	I/O Power Supply	Power supply for the I/O circuitry. Should be connected to a 2.5V \pm 5% power supply.
V _{SSQ}	I/O Ground	Ground for the I/O circuitry. Should be connected to ground of the system.
NC	–	No Connects. Pins are not internally connected.
32M 64m 128M	–	No Connects. Reserved for address expansion.

Introduction

Functional Overview

All synchronous inputs pass through input registers controlled by the rising edge of the clock. All data outputs pass through output registers controlled by the rising edge of the clock. Maximum access delay from the clock rise (t_{CO}) is 3.8 ns (133-MHz device).

The CY7C1380BV25/CY7C1382BV25 supports secondary cache in systems utilizing either a linear or interleaved burst sequence. The interleaved burst order supports Intel® Pentium® and i486™ processors. The linear burst sequence is suited for processors that utilize a linear burst sequence. The burst order is user selectable, and is determined by sampling the MODE input. Accesses can be initiated with either the Processor Address Strobe (ADSP) or the Controller Address Strobe (ADSC). Address advancement through the burst sequence is controlled by the ADV input. A two-bit on-chip wraparound burst counter captures the first address in a burst sequence and automatically increments the address for the rest of the burst access.

Byte write operations are qualified with the Byte Write Enable (BWE) and Byte Write Select ($BW_{a,b,c,d}$ for 1380V25 and $BW_{a,b}$ for 1382V25) inputs. A Global Write Enable (GW) overrides all byte write inputs and writes data to all four bytes. All writes are simplified with on-chip synchronous self-timed write circuitry.

Synchronous Chip Selects (\overline{CE}_1 , CE_2 , \overline{CE}_3 for TQFP / \overline{CE}_1 for BGA) and an asynchronous Output Enable (OE) provide for easy bank selection and output three-state control. ADSP is ignored if \overline{CE}_1 is HIGH.

Single Read Accesses

This access is initiated when the following conditions are satisfied at clock rise: (1) ADSP or ADSC is asserted LOW, (2) chip selects are all asserted active, and (3) the write signals (GW, BWE) are all deasserted HIGH. ADSP is ignored if \overline{CE}_1 is HIGH. The address presented to the address inputs is stored into the address advancement logic and the Address Register while being presented to the memory core. The corresponding data is allowed to propagate to the input of the Output Registers. At the rising edge of the next clock the data is allowed to propagate through the output register and onto the data bus within 3.0 ns (200-MHz device) if OE is active LOW. The only exception occurs when the SRAM is emerging

from a deselected state to a selected state, its outputs are always three-stated during the first cycle of the access. After the first cycle of the access, the outputs are controlled by the OE signal. Consecutive single read cycles are supported. Once the SRAM is deselected at clock rise by the chip select and either ADSP or ADSC signals, its output will three-state immediately.

Single Write Accesses Initiated by \overline{ADSP}

This access is initiated when both of the following conditions are satisfied at clock rise: (1) ADSP is asserted LOW, and (2) chip select is asserted active. The address presented is loaded into the address register and the address advancement logic while being delivered to the RAM core. The write signals (GW, BWE, and BW_x) and ADV inputs are ignored during this first cycle.

\overline{ADSP} triggered write accesses require two clock cycles to complete. If GW is asserted LOW on the second clock rise, the data presented to the DQx inputs is written into the corresponding address location in the RAM core. If \overline{GW} is HIGH, then the write operation is controlled by BWE and BW_x signals. The CY7C1380BV25/CY7C1382BV25 provides byte write capability that is described in the write cycle description table. Asserting the Byte Write Enable input (BWE) with the selected Byte Write ($BW_{a,b,c,d}$ for CY7C1380BV25 and $BW_{a,b}$ for CY7C1382BV25) input will selectively write to only the desired bytes. Bytes not selected during a byte write operation will remain unaltered. A synchronous self-timed write mechanism has been provided to simplify the write operations.

Because the CY7C1380BV25/CY7C1382BV25 is a common I/O device, the Output Enable (\overline{OE}) must be deasserted HIGH before presenting data to the DQ inputs. Doing so will three-state the output drivers. As a safety precaution, DQ are automatically three-stated whenever a write cycle is detected, regardless of the state of \overline{OE} .

Single Write Accesses Initiated by \overline{ADSC}

\overline{ADSC} write accesses are initiated when the following conditions are satisfied: (1) ADSC is asserted LOW, (2) ADSP is deasserted HIGH, (3) chip select is asserted active, and (4) the appropriate combination of the write inputs (GW, BWE, and BW_x) are asserted active to conduct a write to the desired byte(s). ADSC triggered write accesses require a single clock cycle to complete. The address presented to $A_{[17:0]}$ is loaded

into the address register and the address advancement logic while being delivered to the RAM core. The ADV input is ignored during this cycle. If a global write is conducted, the data presented to the DQ_[x:0] is written into the corresponding address location in the RAM core. If a byte write is conducted, only the selected bytes are written. Bytes not selected during a byte write operation will remain unaltered. A synchronous self-timed write mechanism has been provided to simplify the write operations.

Because the CY7C1380BV25/CY7C1382BV25 is a common I/O device, the Output Enable (\overline{OE}) must be deasserted HIGH before presenting data to the DQ_[x:0] inputs. Doing so will three-state the output drivers. As a safety precaution, DQ_[x:0] are automatically three-stated whenever a write cycle is detected, regardless of the state of \overline{OE} .

Burst Sequences

The CY7C1380BV25/CY7C1382BV25 provides a two-bit wraparound counter, fed by A_[1:0], that implements either an interleaved or linear burst sequence. The interleaved burst sequence is designed specifically to support Intel Pentium applications. The linear burst sequence is designed to support processors that follow a linear burst sequence. The burst sequence is user selectable through the MODE input.

Asserting ADV LOW at clock rise will automatically increment the burst counter to the next address in the burst sequence. Both read and write burst operations are supported.

Interleaved Burst Sequence

First Address	Second Address	Third Address	Fourth Address
A _[1:0]	A _[1:0]	A _[1:0]	A _[1:0]
00	01	10	11
01	00	11	10
10	11	00	01
11	10	01	00

Cycle Descriptions [1, 2, 3, 4]

Next Cycle	Add. Used	ZZ	CE ₃	CE ₂	CE ₁	ADSP	ADSC	ADV	OE	DQ	Write
Unselected	None	0	X	X	1	X	0	X	X	Hi-Z	X
Unselected	None	0	1	X	0	0	X	X	X	Hi-Z	X
Unselected	None	0	X	0	0	0	X	X	X	Hi-Z	X
Unselected	None	0	1	X	0	1	0	X	X	Hi-Z	X
Unselected	None	0	X	0	0	1	0	X	X	Hi-Z	X
Begin Read	External	0	0	1	0	0	X	X	X	Hi-Z	X
Begin Read	External	0	0	1	0	1	0	X	X	Hi-Z	Read
Continue Read	Next	0	X	X	X	1	1	0	1	Hi-Z	Read
Continue Read	Next	0	X	X	X	1	1	0	0	DQ	Read
Continue Read	Next	0	X	X	1	X	1	0	1	Hi-Z	Read
Continue Read	Next	0	X	X	1	X	1	0	0	DQ	Read
Suspend Read	Current	0	X	X	X	1	1	1	1	Hi-Z	Read

Note:

1. X = "Don't Care," 1 = HIGH, 0 = LOW.
2. Write is defined by BWE, BW_x, and GW. See Write Cycle Descriptions table.
3. The DQ pins are controlled by the current cycle and the \overline{OE} signal. \overline{OE} is asynchronous and is not sampled with the clock.
4. CE₁, CE₂ and CE₃ are available only in the TQFP package. BGA package has a single chip select CE₁.

Linear Burst Sequence

First Address	Second Address	Third Address	Fourth Address
A _[1:0]	A _[1:0]	A _[1:0]	A _[1:0]
00	01	10	11
01	10	11	00
10	11	00	01
11	00	01	10

Sleep Mode

The ZZ input pin is an asynchronous input. Asserting ZZ places the SRAM in a power conservation "sleep" mode. Two clock cycles are required to enter into or exit from this "sleep" mode. While in this mode, data integrity is guaranteed. Accesses pending when entering the "sleep" mode are not considered valid nor is the completion of the operation guaranteed. The device must be deselected prior to entering the "sleep" mode. CEs, ADSP, and ADSC must remain inactive for the duration of t_{ZZREC} after the ZZ input returns LOW

ZZ Mode Electrical Characteristics

Parameter	Description	Test Conditions	Min.	Max.	Unit
I _{DDZZ}	Sleep mode standby current	ZZ ≥ V _{DD} - 0.2V		20	mA
t _{ZZS}	Device operation to ZZ	ZZ ≥ V _{DD} - 0.2V		2t _{CYC}	ns
t _{ZZREC}	ZZ recovery time	ZZ ≤ 0.2V	2t _{CYC}		ns



Cycle Descriptions (continued)^[1, 2, 3, 4]

Next Cycle	Add. Used	ZZ	CE ₃	CE ₂	CE ₁	ADSP	ADSC	ADV	OE	DQ	Write
Suspend Read	Current	0	X	X	X	1	1	1	0	DQ	Read
Suspend Read	Current	0	X	X	1	X	1	1	1	Hi-Z	Read
Suspend Read	Current	0	X	X	1	X	1	1	0	DQ	Read
Begin Write	Current	0	X	X	X	1	1	1	X	Hi-Z	Write
Begin Write	Current	0	X	X	1	X	1	1	X	Hi-Z	Write
Begin Write	External	0	0	1	0	1	0	X	X	Hi-Z	Write
Continue Write	Next	0	X	X	X	1	1	0	X	Hi-Z	Write
Continue Write	Next	0	X	X	1	X	1	0	X	Hi-Z	Write
Suspend Write	Current	0	X	X	X	1	1	1	X	Hi-Z	Write
Suspend Write	Current	0	X	X	1	X	1	1	X	Hi-Z	Write
ZZ "sleep"	None	1	X	X	X	X	X	X	X	Hi-Z	X

Write Cycle Descriptions^[5, 6, 7]

Function (CY7C1380BV25)	GW	BWE	BWd	BWc	BWb	BWa
Read	1	1	X	X	X	X
Read	1	0	1	1	1	1
Write Byte 0 – DQa	1	0	1	1	1	0
Write Byte 1 – DQb	1	0	1	1	0	1
Write Bytes 1, 0	1	0	1	1	0	0
Write Byte 2 – DQc	1	0	1	0	1	1
Write Bytes 2, 0	1	0	1	0	1	0
Write Bytes 2, 1	1	0	1	0	0	1
Write Bytes 2, 1, 0	1	0	1	0	0	0
Write Byte 3 – DQd	1	0	0	1	1	1
Write Bytes 3, 0	1	0	0	1	1	0
Write Bytes 3, 1	1	0	0	1	0	1
Write Bytes 3, 1, 0	1	0	0	1	0	0
Write Bytes 3, 2	1	0	0	0	1	1
Write Bytes 3, 2, 0	1	0	0	0	1	0
Write Bytes 3, 2, 1	1	0	0	0	0	1
Write All Bytes	1	0	0	0	0	0
Write All Bytes	0	X	X	X	X	X

Function (CY7C1382BV25)	GW	BWE	BWb	BWa
Read	1	1	X	X
Read	1	0	1	1
Write Byte 0 – DQ _[7:0] and DP ₀	1	0	1	0
Write Byte 1 – DQ _[15:8] and DP ₁	1	0	0	1
Write All Bytes	1	0	0	0
Write All Bytes	0	X	X	X

Notes:

- All Voltage referenced to Ground.
- Overshoot: $V_{IH}(AC) \leq V_{DD} + 1.5V$ for $t \leq t_{TCYC}/2$, undershoot: $V_{IL}(AC) \leq 0.5V$ for $t \leq t_{TCYC}/2$, power-up: $V_{IH} < 2.6V$ and $V_{DD} < 2.4V$ and $V_{DDQ} < 1.4V$ for $t < 200$ ms.
- t_{CS} and t_{CH} refer to the set-up and hold time requirements of latching data from the boundary scan register.

IEEE 1149.1 Serial Boundary Scan (JTAG)

The CY7C1380BV25/CY7C1382BV25 incorporates a serial boundary scan Test Access Port (TAP) in the BGA package only. The TQFP package does not offer this functionality. This port operates in accordance with IEEE Standard 1149.1-1900, but does not have the set of functions required for full 1149.1 compliance. These functions from the IEEE specification are excluded because their inclusion places an added delay in the critical speed path of the SRAM. Note that the TAP controller functions in a manner that does not conflict with the operation of other devices using 1149.1 fully compliant TAPs. The TAP operates using JEDEC standard 2.5V I/O logic levels.

Disabling the JTAG Feature

It is possible to operate the SRAM without using the JTAG feature. To disable the TAP controller, TCK must be tied LOW (V_{SS}) to prevent clocking of the device. TDI and TMS are internally pulled up and may be unconnected. They may alternately be connected to V_{DD} through a pull-up resistor. TDO should be left unconnected. Upon power-up, the device will come up in a reset state which will not interfere with the operation of the device.

Test Access Port–Test Clock

The test clock is used only with the TAP controller. All inputs are captured on the rising edge of TCK. All outputs are driven from the falling edge of TCK.

Test Mode Select

The TMS input is used to give commands to the TAP controller and is sampled on the rising edge of TCK. It is allowable to leave this pin unconnected if the TAP is not used. The pin is pulled up internally, resulting in a logic HIGH level.

Test Data-In–(TDI)

The TDI pin is used to serially input information into the registers and can be connected to the input of any of the registers. The register between TDI and TDO is chosen by the instruction that is loaded into the TAP instruction register. For information on loading the instruction register, see the TAP Controller State Diagram. TDI is internally pulled up and can be unconnected if the TAP is unused in an application. TDI is connected to the Most Significant Bit (MSB) on any register.

Test Data Out–(TDO)

The TDO output pin is used to serially clock data-out from the registers. The e output is active depending upon the current state of the TAP state machine (see TAP Controller State Diagram). The output changes on the falling edge of TCK. TDO is connected to the Least Significant Bit (LSB) of any register.

Performing a TAP Reset

A Reset is performed by forcing TMS HIGH (V_{DD}) for five rising edges of TCK. This RESET does not affect the operation of the SRAM and may be performed while the SRAM is operating. At power-up, the TAP is reset internally to ensure that TDO comes up in a high-Z state.

TAP Registers

Registers are connected between the TDI and TDO pins and allow data to be scanned into and out of the SRAM test

circuitry. Only one register can be selected at a time through the instruction registers. Data is serially loaded into the TDI pin on the rising edge of TCK. Data is output on the TDO pin on the falling edge of TCK.

Instruction Register

Three-bit instructions can be serially loaded into the instruction register. This register is loaded when it is placed between the TDI and TDO pins as shown in the TAP Controller Block Diagram. Upon power-up, the instruction register is loaded with the IDCODE instruction. It is also loaded with the IDCODE instruction if the controller is placed in a reset state as described in the previous section.

When the TAP controller is in the CaptureIR state, the two least significant bits are loaded with a binary “01” pattern to allow for fault isolation of the board level serial test path.

Bypass Register

To save time when serially shifting data through registers, it is sometimes advantageous to skip certain states. The bypass register is a single-bit register that can be placed between TDI and TDO pins. This allows data to be shifted through the SRAM with minimal delay. The bypass register is set LOW (V_{SS}) when the BYPASS instruction is executed.

Boundary Scan Register

The boundary scan register is connected to all the input and output pins on the SRAM. Several no connect (NC) pins are also included in the scan register to reserve pins for higher density devices. The x36 configuration has a xx-bit-long register, and the x18 configuration has a yy-bit-long register.

The boundary scan register is loaded with the contents of the RAM Input and Output ring when the TAP controller is in the Capture-DR state and is then placed between the TDI and TDO pins when the controller is moved to the Shift-DR state. The EXTEST, SAMPLE/PRELOAD and SAMPLE Z instructions can be used to capture the contents of the Input and Output ring.

The Boundary Scan Order tables show the order in which the bits are connected. Each bit corresponds to one of the bumps on the SRAM package. The MSB of the register is connected to TDI, and the LSB is connected to TDO.

Identification (ID) Register

The ID register is loaded with a vendor-specific, 32-bit code during the Capture-DR state when the IDCODE command is loaded in the instruction register. The IDCODE is hardwired into the SRAM and can be shifted out when the TAP controller is in the Shift-DR state. The ID register has a vendor code and other information described in the Identification Register Definitions table.

TAP Instruction Set

Eight different instructions are possible with the three-bit instruction register. All combinations are listed in the Instruction Code table. Three of these instructions are listed as RESERVED and should not be used. The other five instructions are described in detail below.

The TAP controller used in this SRAM is not fully compliant to the 1149.1 convention because some of the mandatory 1149.1 instructions are not fully implemented. The TAP controller cannot be used to load address, data or control signals into the

SRAM and cannot preload the Input or Output buffers. The SRAM does not implement the 1149.1 commands EXTEST or INTEST or the PRELOAD portion of SAMPLE / PRELOAD; rather it performs a capture of the Inputs and Output ring when these instructions are executed.

Instructions are loaded into the TAP controller during the Shift-IR state when the instruction register is placed between TDI and TDO. During this state, instructions are shifted through the instruction register through the TDI and TDO pins. To execute the instruction once it is shifted in, the TAP controller needs to be moved into the Update-IR state.

EXTEST

EXTEST is a mandatory 1149.1 instruction which is to be executed whenever the instruction register is loaded with all 0s. EXTEST is not implemented in the TAP controller, and therefore this device is not compliant to the 1149.1 standard.

The TAP controller does not recognize an all-0 instruction. When an EXTEST instruction is loaded into the instruction register, the SRAM responds as if a SAMPLE/PRELOAD instruction has been loaded. There is one difference between the two instructions. Unlike the SAMPLE/PRELOAD instruction, EXTEST places the SRAM outputs in a High-Z state.

IDCODE

The IDCODE instruction causes a vendor-specific, 32-bit code to be loaded into the instruction register. It also places the instruction register between the TDI and TDO pins and allows the IDCODE to be shifted out of the device when the TAP controller enters the Shift-DR state. The IDCODE instruction is loaded into the instruction register upon power-up or whenever the TAP controller is given a test logic reset state.

SAMPLE Z

The SAMPLE Z instruction causes the boundary scan register to be connected between the TDI and TDO pins when the TAP controller is in a Shift-DR state. It also places all SRAM outputs into a High-Z state.

SAMPLE/PRELOAD

SAMPLE/PRELOAD is a 1149.1 mandatory instruction. The PRELOAD portion of this instruction is not implemented, so the TAP controller is not fully 1149.1-compliant.

When the SAMPLE/PRELOAD instructions loaded into the instruction register and the TAP controller in the Capture-DR state, a snapshot of data on the inputs and output pins is captured in the boundary scan register.

The user must be aware that the TAP controller clock can only operate at a frequency up to 10 MHz, while the SRAM clock operates more than an order of magnitude faster. Because there is a large difference in the clock frequencies, it is possible that during the Capture-DR state, an input or output will undergo a transition. The TAP may then try to capture a signal while in transition (metastable state). This will not harm the device, but there is no guarantee as to the value that will be captured. Repeatable results may not be possible.

To guarantee that the boundary scan register will capture the correct value of a signal, the SRAM signal must be stabilized long enough to meet the TAP controller's capture set-up plus hold times (t_{CS} and t_{CH}). The SRAM clock input might not be captured correctly if there is no way in a design to stop (or slow) the clock during a SAMPLE/PRELOAD instruction. If this is an issue, it is still possible to capture all other signals and simply ignore the value of the CK and \overline{CK} captured in the boundary scan register.

Once the data is captured, it is possible to shift out the data by putting the TAP into the Shift-DR state. This places the boundary scan register between the TDI and TDO pins.

Note that since the PRELOAD part of the command is not implemented, putting the TAP into the Update-DR state while performing a SAMPLE/PRELOAD instruction will have the same effect as the Pause-DR command.

Bypass

When the BYPASS instruction is loaded in the instruction register and the TAP is placed in a Shift-DR state, the bypass register is placed between the TDI and TDO pins. The advantage of the BYPASS instruction is that it shortens the boundary scan path when multiple devices are connected together on a board.

Reserved

These instructions are not implemented but are reserved for future use. Do not use these instructions.

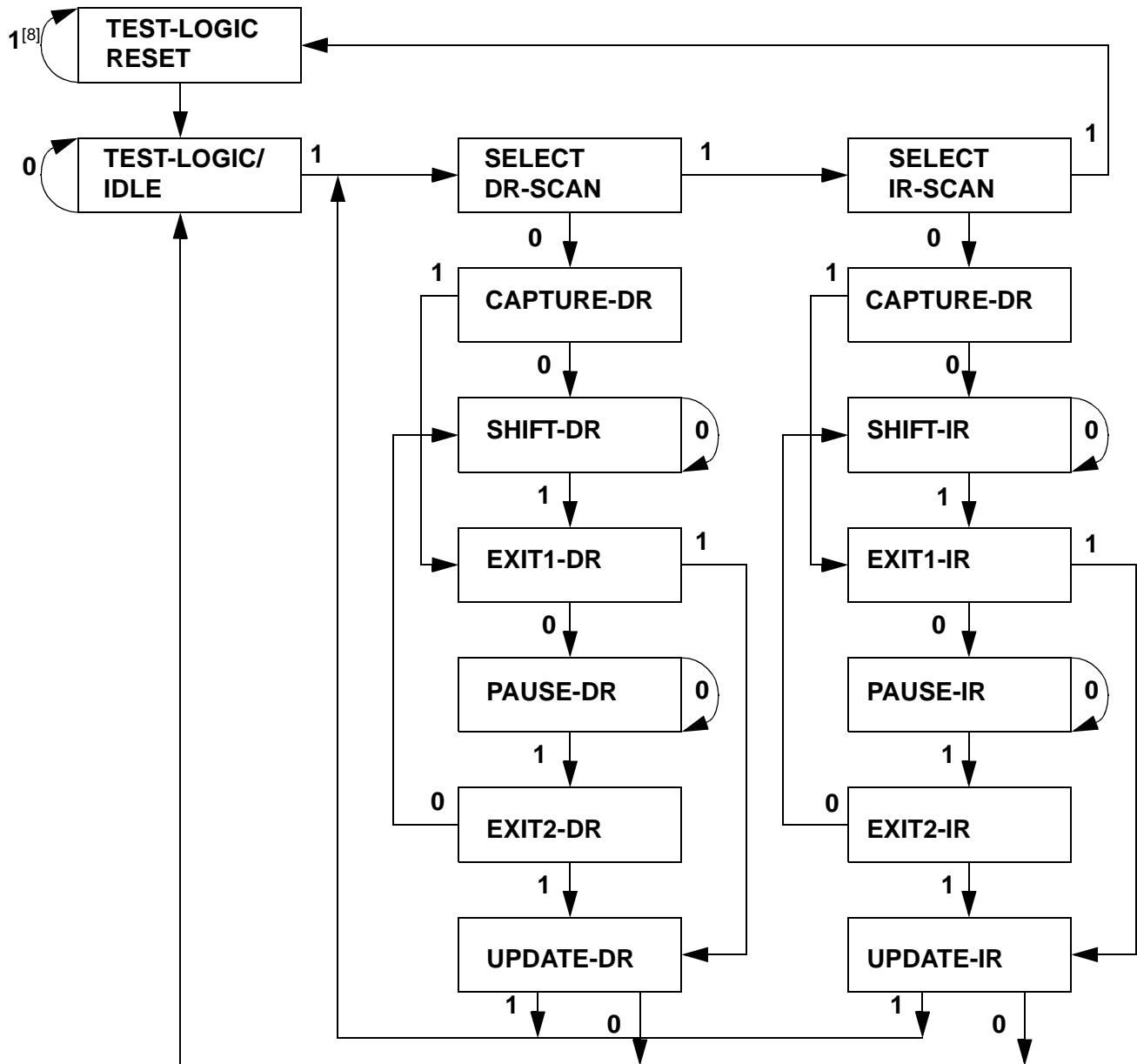
TAP Controller State Diagram

Note:

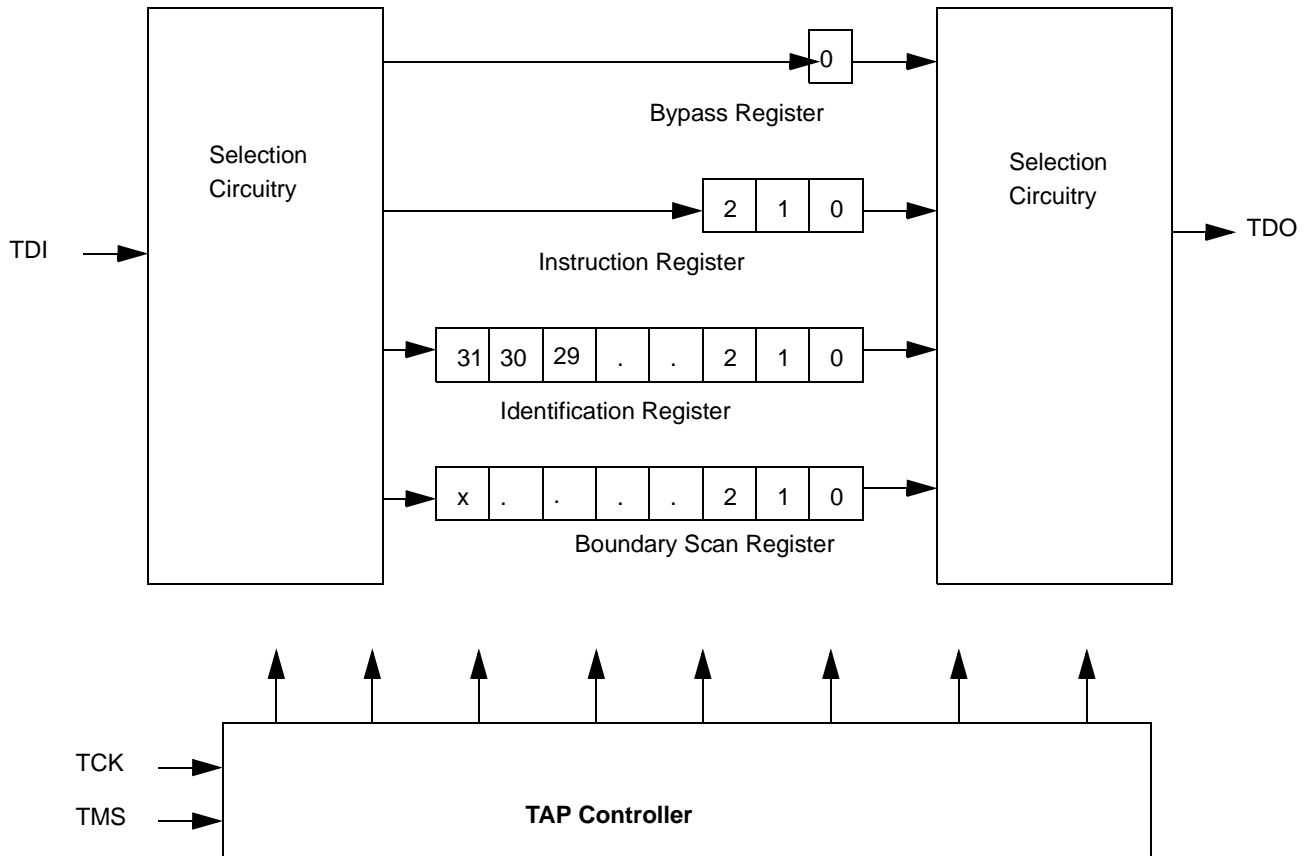
8. The "0"/"1" next to each state represents the value at TMS at the rising edge of TCK.

TAP Controller Block Diagram

TAP Electrical Characteristics Over the Operating Range^[5, 6]

Parameter	Description	Test Conditions	Min.	Max.	Unit
V _{OH1}	Output HIGH Voltage	I _{OH} = -4.0 mA	2.0		V
V _{OH2}	Output HIGH Voltage	I _{OH} = -100 μA	V _{DD} -0.2		V
V _{OL1}	Output LOW Voltage	I _{OL} = 8.0 mA		0.4	V
V _{OL2}	Output LOW Voltage	I _{OL} = 100 μA		0.2	V
V _{IH}	Input HIGH Voltage		1.7	V _{DD} +0.3	V
V _{IL}	Input LOW Voltage		-0.3	0.7	V
I _X	Input Load Current	GND ≤ V _I ≤ V _{DDQ}	-5	5	μA

TAP AC Switching Characteristics Over the Operating Range ^[7, 9]

Parameters	Description	Min.	Max.	Unit
t _{TCYC}	TCK Clock Cycle Time	100		ns
t _{TF}	TCK Clock Frequency		10	MHz
t _{TH}	TCK Clock HIGH	40		ns
t _{TL}	TCK Clock LOW	40		ns
Set-up Times				
t _{TMSS}	TMS Set-up to TCK Clock Rise	10		ns
t _{TDIS}	TDI Set-up to TCK Clock Rise	10		ns
t _{CS}	Capture Set-up to TCK Rise	10		ns

Note:

9. Test conditions are specified using the load in TAP AC test conditions. t_R/t_F = 1 ns.

TAP AC Switching Characteristics Over the Operating Range (continued)^[7, 9]

Parameters	Description	Min.	Max.	Unit
Hold Times				
t_{TMSH}	TMS Hold after TCK Clock Rise	10		ns
t_{TDIH}	TDI Hold after Clock Rise	10		ns
t_{CH}	Capture Hold after Clock Rise	10		ns
Output Times				
t_{TDOV}	TCK Clock LOW to TDO Valid		20	ns
t_{TDOX}	TCK Clock HIGH to TDO Invalid	0		ns

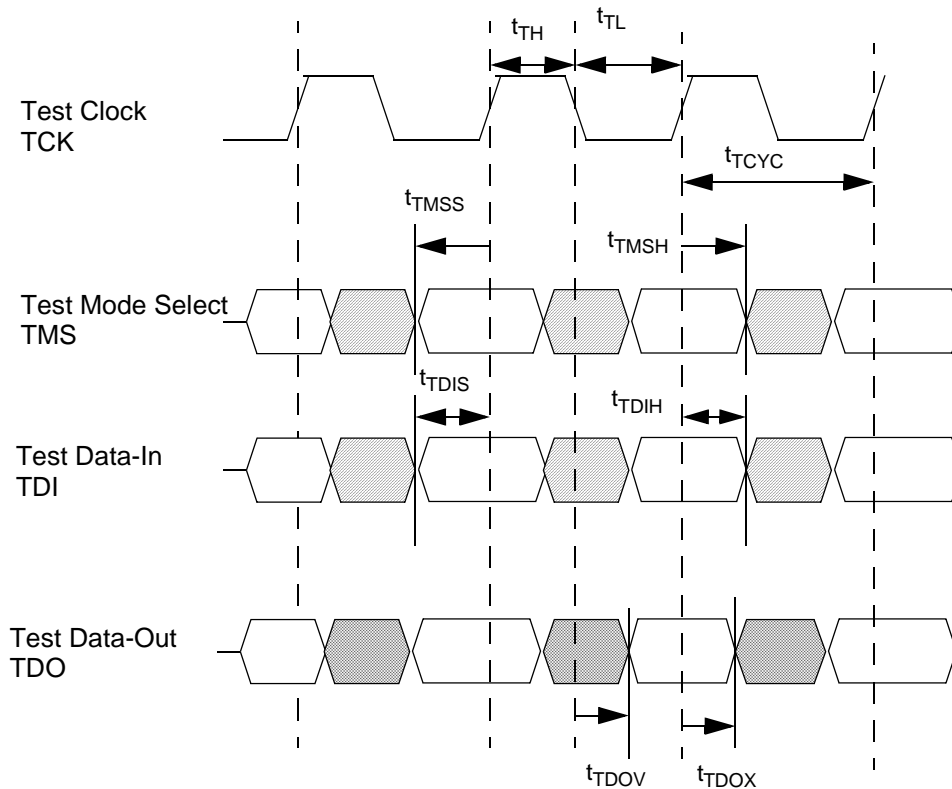
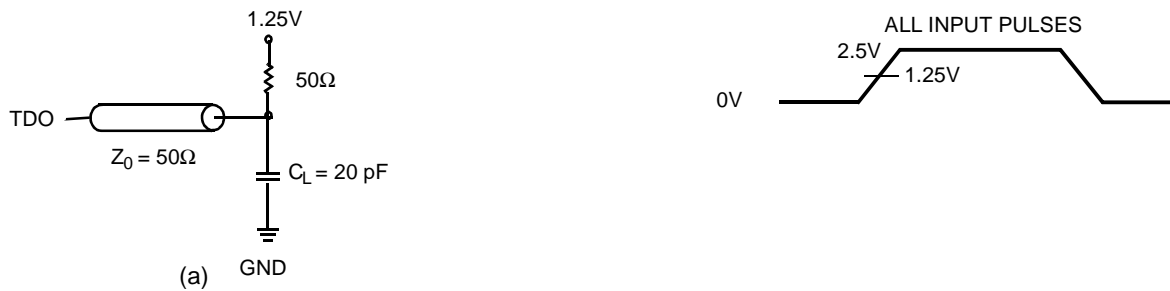
TAP Timing and Test Conditions

Identification Register Definitions

Instruction Field	512K x 36	1M x 18	Description
Revision Number (31:28)	xxxx	xxxx	Reserved for version number.
Device Depth (27:23)	00111	01000	Defines depth of SRAM. 512K or 1M
Device Width (22:18)	00100	00011	Defines with of the SRAM. x36 or x18
Cypress Device ID (17:12)	xxxxx	xxxxx	Reserved for future use.
Cypress JEDEC ID (11:1)	00011100100	00011100100	Allows unique identification of SRAM vendor.
ID Register Presence (0)	1	1	Indicate the presence of an ID register.

Scan Register Sizes

Register Name	Bit Size (x18)	Bit Size (x36)
Instruction	3	3
Bypass	1	1
ID	32	32
Boundary Scan	51	70

Identification Codes

Instruction	Code	Description
EXTEST	000	Captures the Input/Output ring contents. Places the boundary scan register between the TDI and TDO. Forces all SRAM outputs to High-Z state. This instruction is not 1149.1-compliant.
IDCODE	001	Loads the ID register with the vendor ID code and places the register between TDI and TDO. This operation does not affect SRAM operation.
SAMPLE Z	010	Captures the Input/Output contents. Places the boundary scan register between TDI and TDO. Forces all SRAM output drivers to a High-Z state.
RESERVED	011	Do Not Use: This instruction is reserved for future use.
SAMPLE/PRELOAD	100	Captures the Input/Output ring contents. Places the boundary scan register between TDI and TDO. Does not affect the SRAM operation. This instruction does not implement 1149.1 preload function and is therefore not 1149.1-compliant.
RESERVED	101	Do Not Use: This instruction is reserved for future use.
RESERVED	110	Do Not Use: This instruction is reserved for future use.
BYPASS	111	Places the bypass register between TDI and TDO. This operation does not affect SRAM operation.

Boundary Scan Order (512K x 36)

Bit #	Signal Name	Bump ID	Bit #	Signal Name	Bump ID
1	A	2R	36	A	6B
2	A	3T	37	BWa	5L
3	A	4T	38	BWb	5G
4	A	5T	39	BWc	3G
5	A	6R	40	BWd	3L
6	A	3B	41	A	2B
7	A	5B	42	CE	4E
8	DQa	6P	43	A	3A
9	DQa	7N	44	A	2A
10	DQa	6M	45	DQc	2D
11	DQa	7L	46	DQc	1E
12	DQa	6K	47	DQc	2F
13	DQa	7P	48	DQc	1G
14	DQa	6N	49	DQc	1D
15	DQa	6L	50	DQc	1D
16	DQa	7K	51	DQc	2E
17	ZZ	7T	52	DQc	2G
18	DQb	6H	53	DQc	1H
19	DQb	7G	54	NC	5R
20	DQb	6F	55	DQd	2K
21	DQb	7E	56	DQd	1L
22	DQb	6D	57	DQd	2M
23	DQb	7H	58	DQd	1N
24	DQb	6G	59	DQd	2P
25	DQb	6E	60	DQd	1K
26	DQb	7D	61	DQd	2L
27	A	6A	62	DQd	2N
28	A	5A	63	DQd	1P
29	ADV	4G	64	MODE	3R
30	ADSP	4A	65	A	2C
31	ADSC	4B	66	A	3C
32	OE	4F	67	A	5C
33	BWE	4M	68	A	6C
34	GW	4H	69	A1	4N
35	CLK	4K	70	A0	4P

Boundary Scan Order (1M x 18)

Bit #	Signal Name	Bump ID	Bit #	Signal Name	Bump ID
1	A	2R	36	DQb	2E
2	A	2T	37	DQb	2G
3	A	3T	38	DQb	1H
4	A	5T	39	NC	5R
5	A	6R	40	DQb	2K
6	A	3B	41	DQb	1L
7	A	5B	42	DQb	2M
8	DQa	7P	43	DQb	1N
9	DQa	6N	44	DQb	2P
10	DQa	6L	45	MODE	3R
11	DQa	7K	46	A	2C
12	ZZ	7T	47	A	3C
13	DQa	6H	48	A	5C
14	DQa	7G	49	A	6C
15	DQa	6F	50	A1	4N
16	DQa	7E	51	A0	4P
17	DQa	6D			
18	A	6T			
19	A	6A			
20	A	5A			
21	ADV	4G			
22	ADSP	4A			
23	ADSC	4B			
24	OE	4F			
25	BWE	4M			
26	GW	4H			
27	CLK	4K			
28	A	6B			
29	BWa	5L			
30	BWb	3G			
31	A	2B			
32	CE	4E			
33	A	3A			
34	A	2A			
35	DQb	1D			



Maximum Ratings

(Above which the useful life may be impaired. For user guidelines, not tested.)

Storage Temperature -55°C to +150°C
 Ambient Temperature with Power Applied..... -55°C to +125°C
 Supply Voltage on V_{DD} Relative to GND -0.3V to +3.6V
 DC Voltage Applied to Outputs in High-Z State^[10] -0.5V to V_{DDQ} + 0.5V
 DC Input Voltage^[10] -0.5V to V_{DDQ} + 0.5V

Current into Outputs (LOW)..... 20 mA
 Static Discharge Voltage > 1500V (per MIL-STD-883, Method 3015)
 Latch-up Current..... > 200 mA

Operating Range

Range	Ambient Temperature ^[11]	V _{DD} /V _{DDQ} ^[12]
Commercial	0°C to +70°C	2.5V ± 5%
Industrial	-40°C to +85°C	

Electrical Characteristics Over the Operating Range

Parameter	Description	Test Conditions	Min.	Max.	Unit
V _{DD} /V _{DDQ}	Power Supply Voltage	2.5V range	2.375	2.625	V
V _{OH}	Output HIGH Voltage	V _{DD} = Min., I _{OH} = -1.0 mA	2.0		V
V _{OL}	Output LOW Voltage	V _{DD} = Min., I _{OL} = 1.0 mA		0.4	V
V _{IH}	Input HIGH Voltage		1.7		V
V _{IL}	Input LOW Voltage ^[10]		-0.3	0.7	V
I _X	Input Load Current	GND ≤ V _I ≤ V _{DDQ}		5	μA
I _{ZZ}	Input Current of MODE		-30	30	μA
	Input Current of ZZ	Input = V _{SS}	-30	30	μA
I _{OZ}	Output Leakage Current	GND ≤ V _I ≤ V _{DDQ} , Output Disabled		5	μA
I _{DD}	V _{DD} Operating Supply	V _{DD} = Max., I _{OUT} = 0 mA, f = f _{MAX} = 1/t _{CYC}	5.0-ns cycle, 200 MHz	280	mA
			6.0-ns cycle, 167 MHz	230	mA
			6.7-ns cycle, 150 MHz	190	mA
			7.5-ns cycle, 133 MHz	160	mA
I _{SB1}	Automatic CE Power-Down Current—TTL Inputs	Max. V _{DD} , Device Deselected, V _{IN} ≥ V _{IH} or V _{IN} ≤ V _{IL} , f = f _{MAX} = 1/t _{CYC}	5.0-ns cycle, 200 MHz	100	mA
			6.0-ns cycle, 167 MHz	80	mA
			6.7-ns cycle, 150 MHz	65	mA
			7.5-ns cycle, 133 MHz	60	mA
I _{SB2}	Automatic CE Power-Down Current—CMOS Inputs	Max. V _{DD} , Device Deselected, V _{IN} ≤ 0.3V or V _{IN} ≥ V _{DDQ} - 0.3V, f = 0		30	mA
I _{SB3}	Automatic CE Power-Down Current—CMOS Inputs	Max. V _{DD} , Device Deselected, or V _{IN} ≤ 0.3V or V _{IN} ≥ V _{DDQ} - 0.3V, f = f _{MAX} = 1/t _{CYC}	5.0-ns cycle, 200 MHz	90	mA
			6.0-ns cycle, 167MHz	70	mA
			6.7-ns cycle, 150 MHz	60	mA
			7.5-ns cycle, 133 MHz	55	mA
I _{SB4}	Automatic CE Power-Down Current—TTL Inputs	Max. V _{DD} , Device Deselected, V _{IN} ≥ V _{IH} or V _{IN} ≤ V _{IL} , f = 0		50	mA

Notes:

- 10. Minimum voltage equals -2.0V for pulse durations of less than 20 ns.
- 11. T_A is the temperature.
- 12. Power Supply ramp up should be monotonic.

Capacitance^[13]

Parameter	Description	Test Conditions	Max.	Unit
C _{IN}	Input Capacitance	T _A = 25°C, f = 1 MHz, V _{DD} = 3.3V, V _{DDQ} = 2.5V	3	pF
C _{CLK}	Clock Input Capacitance		3	pF
C _{I/O}	Input/Output Capacitance		3	pF

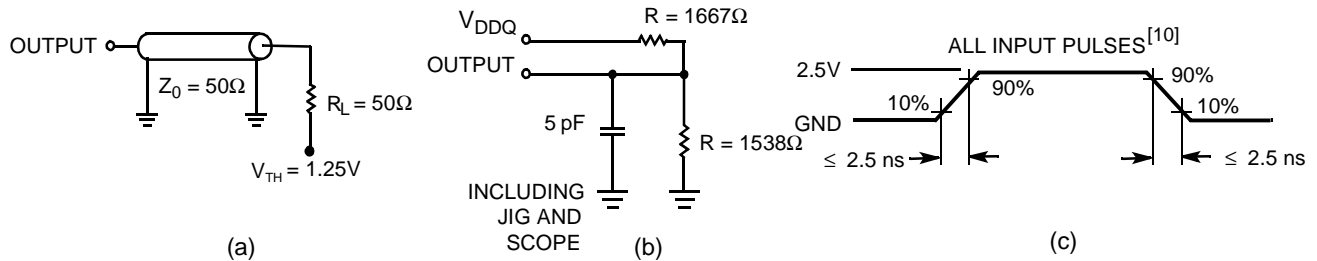
AC Test Loads and Waveforms^[14]

Thermal Resistance^[13]

Description	Test Conditions	Θ _{JA} (Junction to Ambient)	Θ _{JC} (Junction to Case)	Unit
119-ball BGA	Still Air, soldered on a 114.3 x 101.6 x 1.57 mm ³ , 2-layer board	41.54	6.33	°C/W
165-ball FBGA		44.51	2.38	°C/W
100-pin TQFP	Still Air, soldered on a 4.25 x 1.125 inch, 4-layer printed circuit board	25	9	°C/W

Switching Characteristics Over the Operating Range^[15, 16, 17]

Parameter	Description	-200		^a -167		-150		-133		Unit
		Min.	Max.	Min.	Max.	Min.	Max.	Min.	Max.	
t _{CYC}	Clock Cycle Time	5.0		6.0		6.7		7.5		ns
t _{CH}	Clock HIGH	1.8		2.1		2.3		2.5		ns
t _{CL}	Clock LOW	1.8		2.1		2.3		2.5		ns
t _{AS}	Address Set-up Before CLK Rise	1.4		1.5		1.5		1.5		ns
t _{AH}	Address Hold After CLK Rise	0.4		0.5		0.5		0.5		ns
t _{CO}	Data Output Valid After CLK Rise		3.0		3.4		3.8		4.2	ns
t _{DOH}	Data Output Hold After CLK Rise	1.3		1.3		1.3		1.3		ns
t _{ADS}	ADSP, ADSC Set-up Before CLK Rise	1.4		1.5		1.5		1.5		ns
t _{ADH}	ADSP, ADSC Hold After CLK Rise	0.4		0.5		0.5		0.5		ns
t _{WES}	BWE, GW, BW _x Set-up Before CLK Rise	1.4		1.5		1.5		1.5		ns
t _{WEH}	BWE, GW, BW _x Hold After CLK Rise	0.4		0.5		0.5		0.5		ns
t _{ADVS}	ADV Set-up Before CLK Rise	1.4		1.5		1.5		1.5		ns
t _{ADVH}	ADV Hold After CLK Rise	0.4		0.5		0.5		0.5		ns
t _{DS}	Data Input Set-up Before CLK Rise	1.4		1.5		1.5		1.5		ns
t _{DH}	Data Input Hold After CLK Rise	0.4		0.5		0.5		0.5		ns

Notes:

- Tested initially and after any design or process changes that may affect these parameters.
- Input waveform should have a slew rate of 1 V/ns.
- Unless otherwise noted, test conditions assume signal transition time of 2.5 ns or less, timing reference levels of 1.25V, input pulse levels of 0 to 2.5V, and output loading of the specified I_{OL}/I_{OH} and load capacitance. Shown in (a), (b) and (c) of AC test loads.
- t_{CHZ}, t_{CLZ}, t_{OEZ}, t_{EOHZ}, and t_{EOHZ} are specified with a load capacitance of 5 pF as in part (b) of AC Test Loads. Transition is measured ± 200 mV from steady-state voltage.
- At any given voltage and temperature, t_{EOHZ} is less than t_{EOHZ} and t_{CHZ} is less than t_{CLZ}.



Switching Characteristics Over the Operating Range (continued)^[15, 16, 17]

Parameter	Description	-200		^a -167		-150		-133		Unit
		Min.	Max.	Min.	Max.	Min.	Max.	Min.	Max.	
t _{CES}	Chip enable Set-up	1.4		1.5		1.5		1.5		ns
t _{CEH}	Chip enable Hold After CLK Rise	0.4		0.5		0.5		0.5		ns
t _{CHZ}	Clock to High-Z ^[16]		3.0		3.0		3.0		3.0	ns
t _{CLZ}	Clock to Low-Z ^[16]	1.3		1.3		1.3		1.3		ns
t _{EOHZ}	OE HIGH to Output High-Z ^[16, 17]		4.0		3.5		4.0		4.0	ns
t _{EOLZ}	OE LOW to Output Low-Z ^[16, 17]	0		0		0		0		ns
t _{EOV}	OE LOW to Output Valid ^[16]		3.0		3.5		3.8		4.2	ns

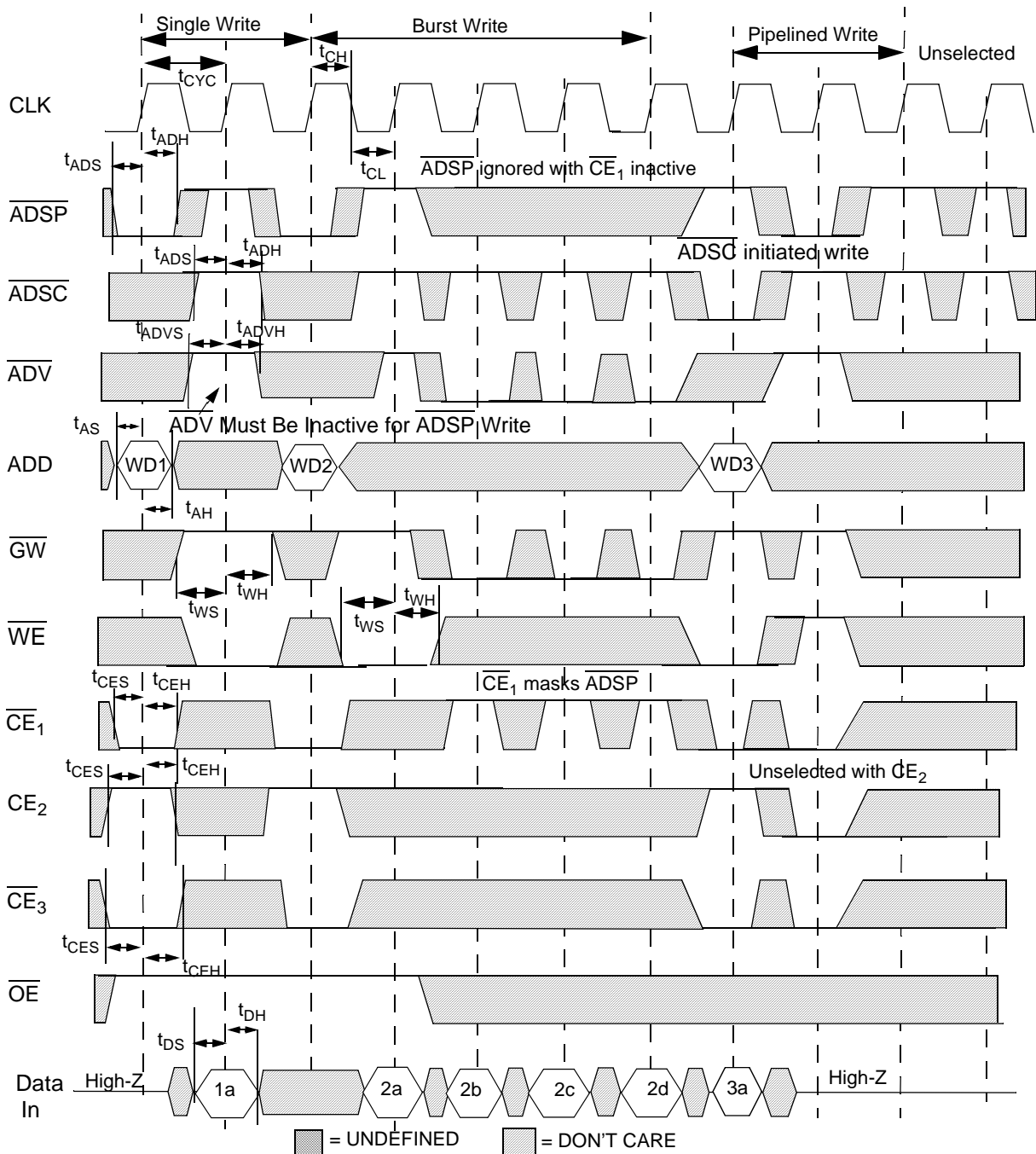
Switching Waveforms
Write Cycle Timing^[4, 18, 19]

Notes:

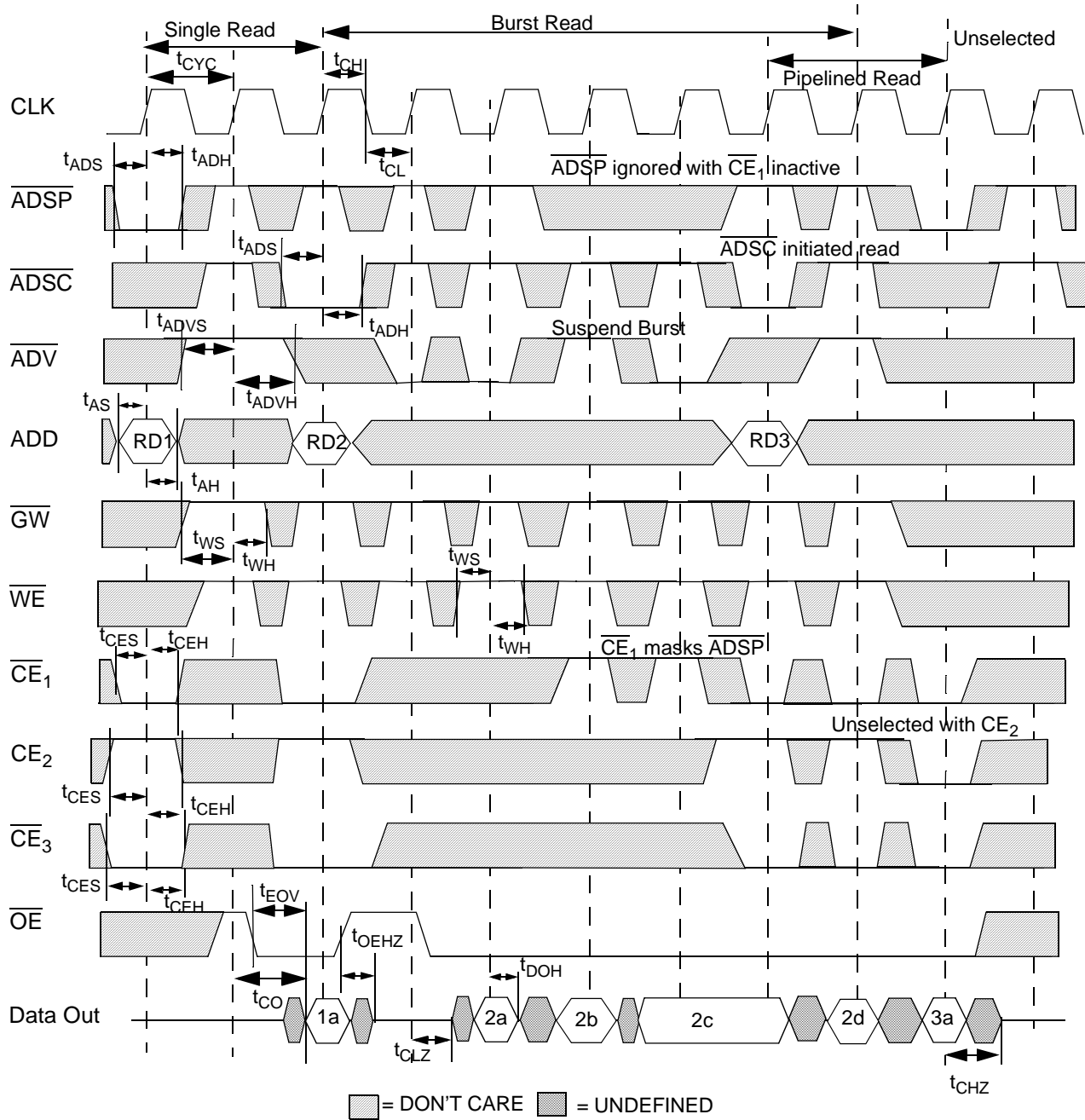
18. \overline{WE} is the combination of \overline{BWE} , \overline{BWx} and \overline{GW} to define a write cycle (see Write Cycle Descriptions table).
 19. WDx stands for Write Data to Address X.

Switching Waveforms (continued)
Read Cycle Timing^[4, 18, 20]

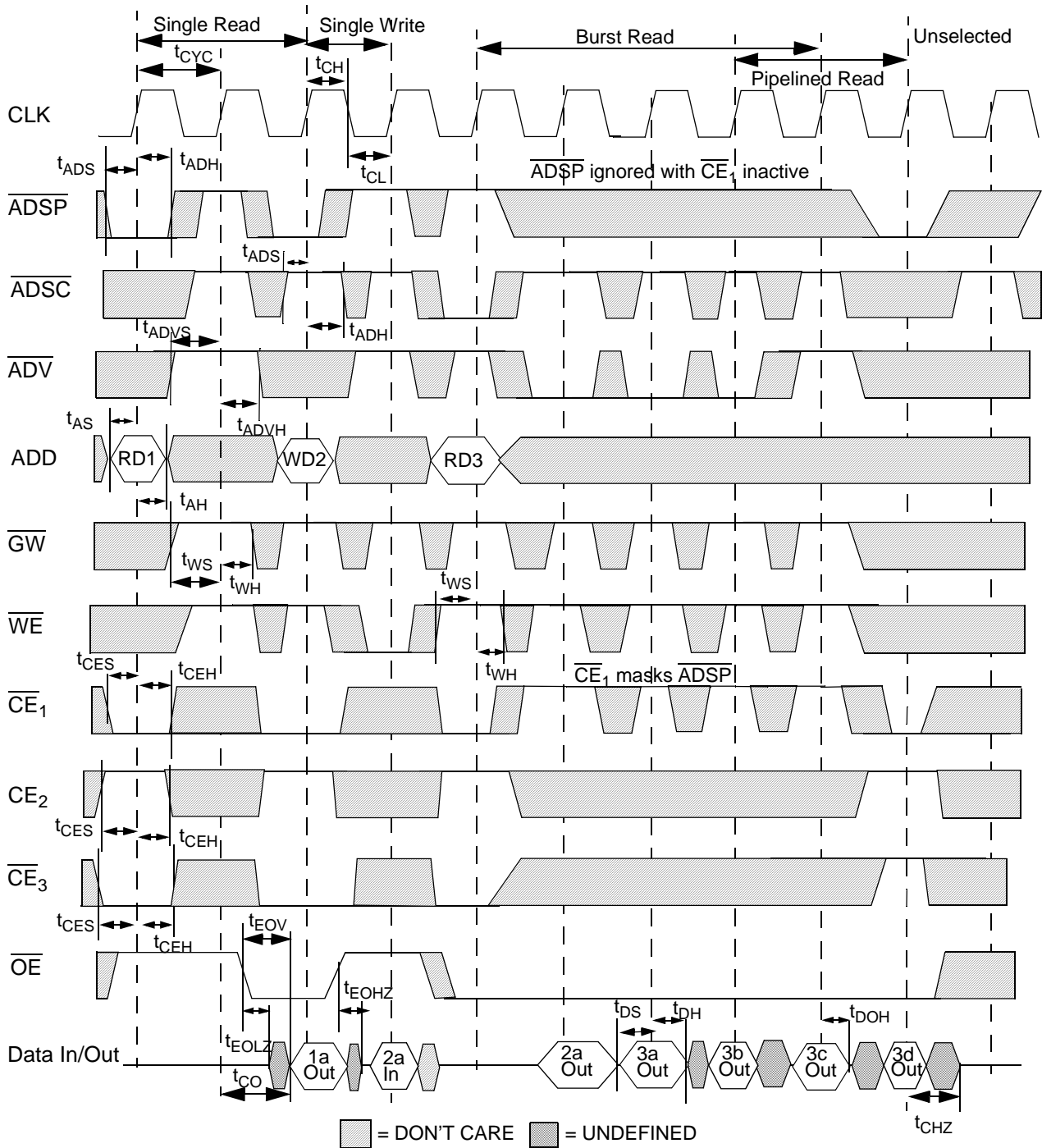
Note:
 20. RDx stands for Read Data from Address X.

Switching Waveforms (continued)
Read/Write Cycle Timing^[4, 18, 19, 20]

Switching Waveforms (continued)

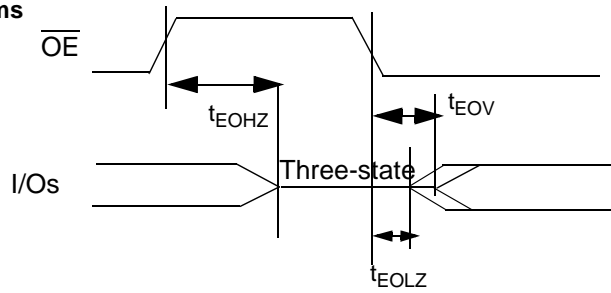
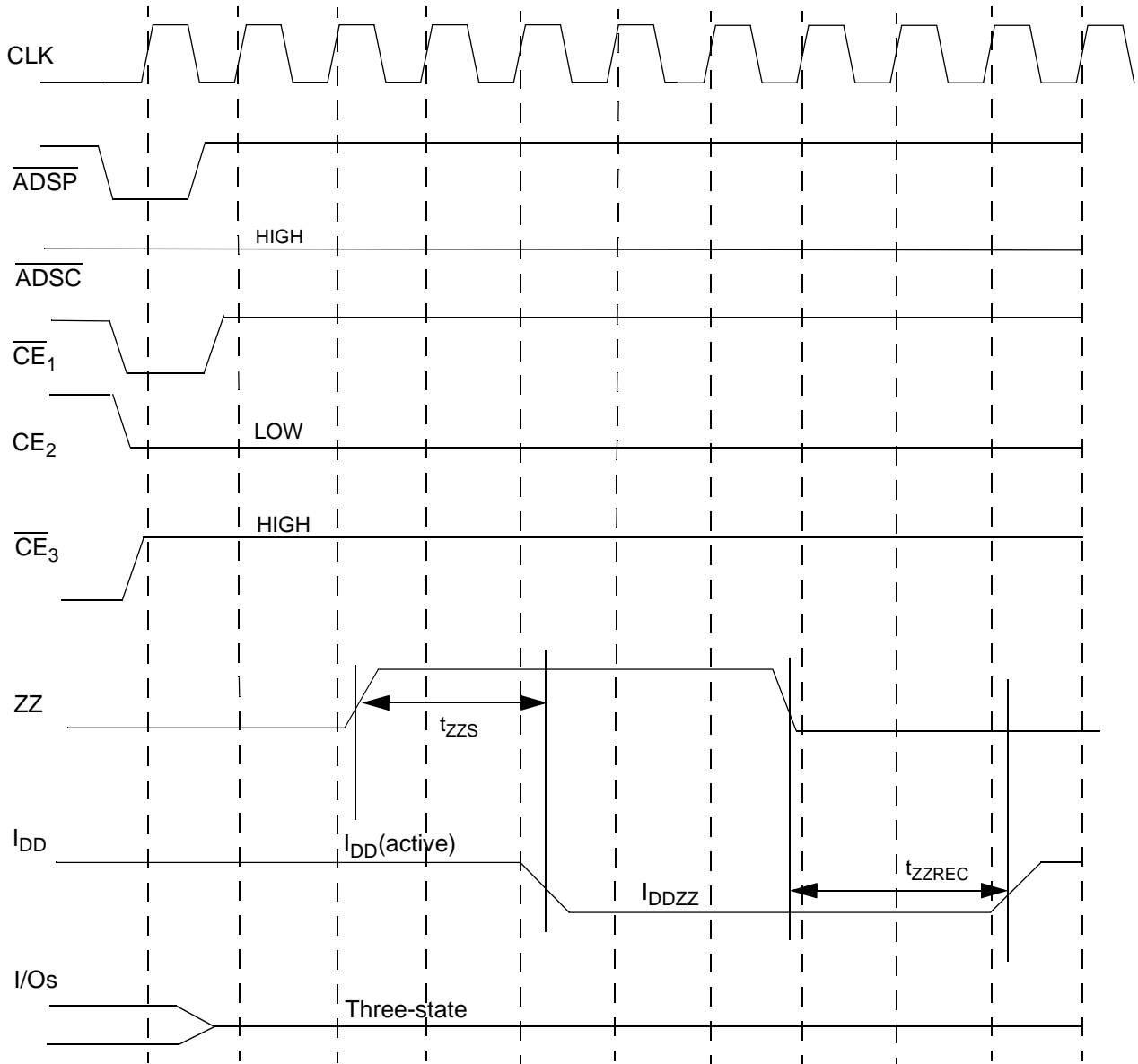
OE Switching Waveforms

ZZ Mode Timing^[4, 21, 22]

Note:

21. Device must be deselected when entering ZZ mode. See Cycle Descriptions Table for all possible signal conditions to deselect the device.
22. I/Os are in three-state when exiting ZZ sleep mode.

Ordering Information

Speed (MHz)	Ordering Code	Package Name	Package Type	Operating Range
200	CY7C1380BV25-200AC	A101	100-lead Thin Quad Flat Pack	Commercial
167	CY7C1380BV25-167AC			
150	CY7C1380BV25-150AC			
133	CY7C1380BV25-133AC			
200	CY7C1380BV25-200BGC	BG119	119-ball BGA	
167	CY7C1380BV25-167BGC			
150	CY7C1380BV25-150BGC			
133	CY7C1380BV25-133BGC			
200	CY7C1380BV25-200BZC	BA165A	165-ball FBGA	
167	CY7C1380BV25-167BZC			
150	CY7C1380BV25-150BZC			
133	CY7C1380BV25-133BZC			
167	CY7C1380BV25-167AI	A101	100-lead Thin Quad Flat Pack	Industrial
150	CY7C1380BV25-150AI			
133	CY7C1380BV25-133AI			
167	CY7C1380BV25-167BGI	BG119	119-ball BGA	
150	CY7C1380BV25-150BGI			
133	CY7C1380BV25-133BGI			
167	CY7C1380BV25-167BZI	BA165A	165-ball FBGA	
150	CY7C1380BV25-150BZI			
133	CY7C1380BV25-133BZI			

Shaded areas contain advance information.

Package Diagrams

100-pin Thin Plastic Quad Flatpack (14 x 20 x 1.4 mm) A101

DIMENSIONS ARE IN MILLIMETERS.

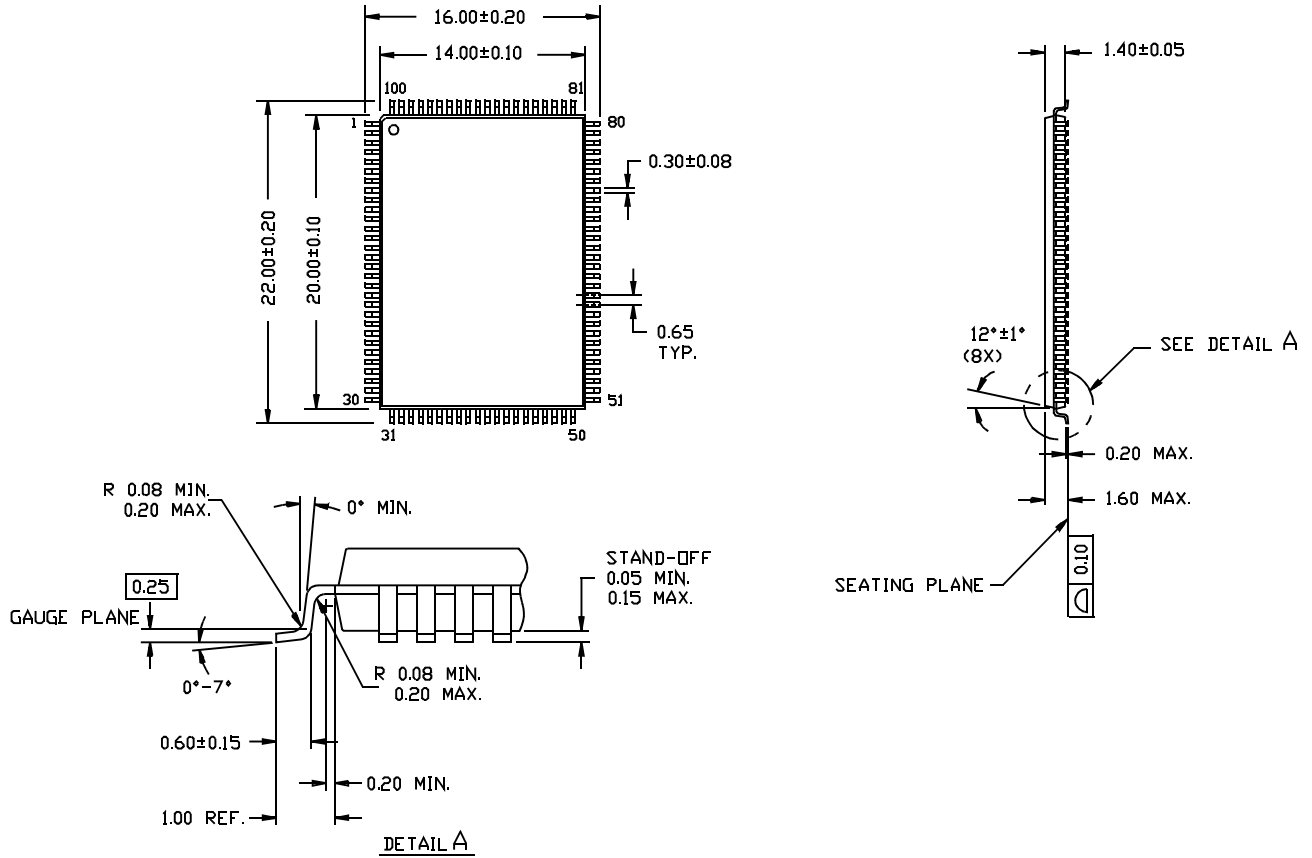

51-85050-A

Package Diagrams (continued)

119-Lead PBGA (14 x 22 x 2.4 mm) BG119

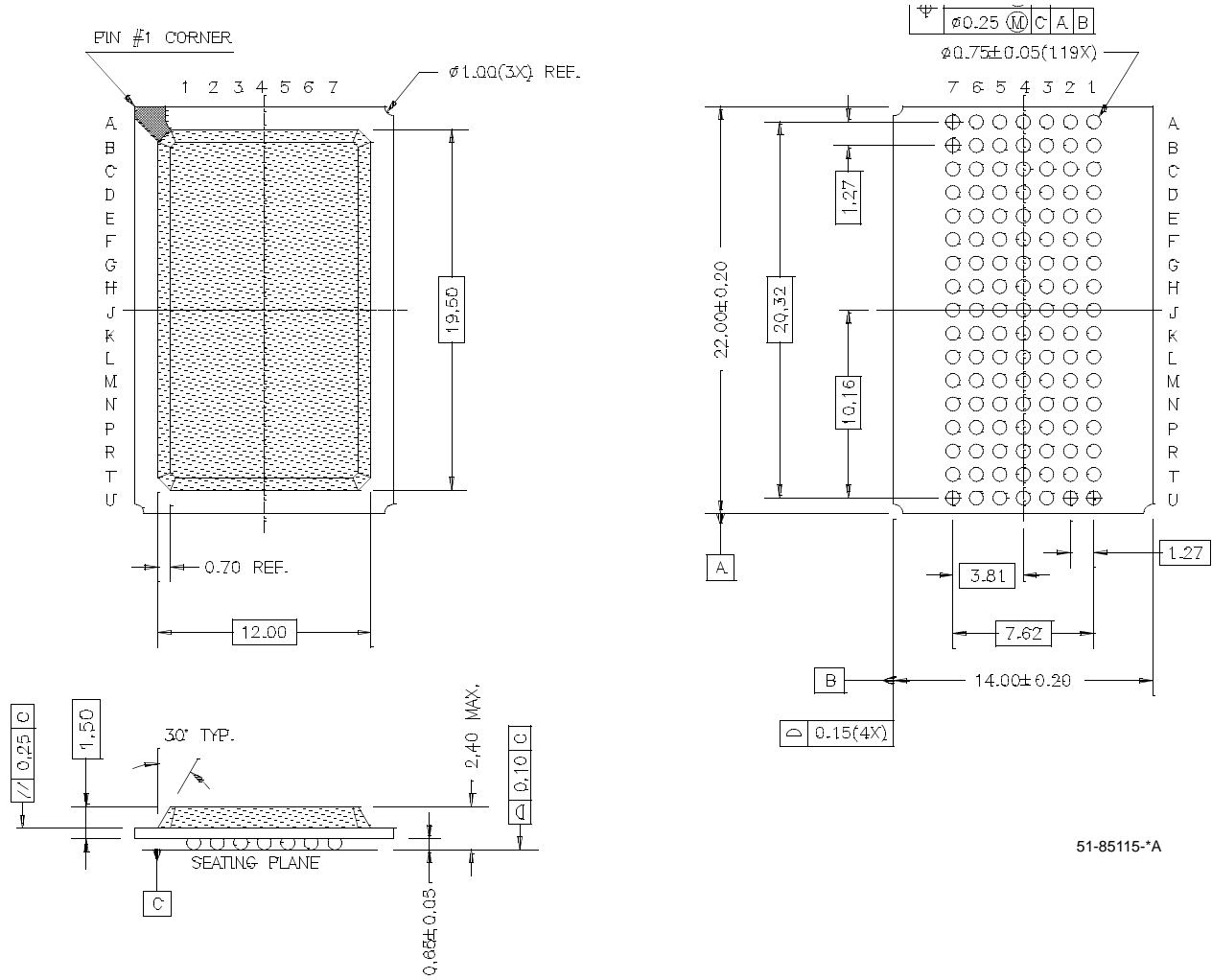

51-85115-A

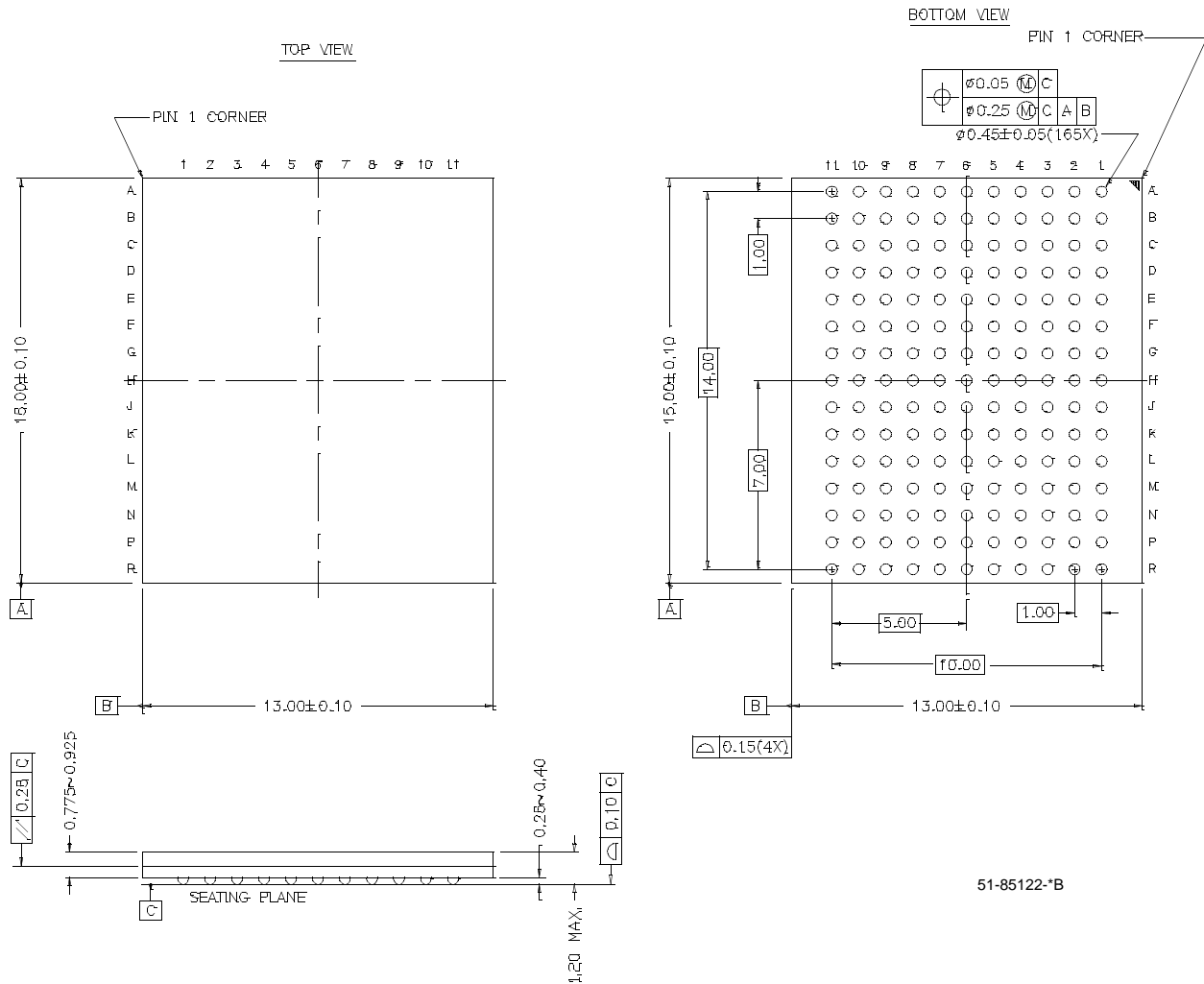
Package Diagrams (continued)
165-Ball FBGA (13 x 15 x 1.2 mm) BB165A

Intel and Pentium are registered trademarks, and i486 is a trademark, of Intel Corporation. All product and company names mentioned in this document are the trademarks of their respective holders.

Document Title: CY7C1380BV25/CY7C1382BV25 512K x 36 / 1M x 18 Pipelined SRAM
Document Number: 38-05251

REV.	ECN No.	Issue Date	Orig. of Change	Description of Change
**	113653	05/02/02	CJM	Changed Spec from: 38-01075 to 38-05251 Added ZZ pin functionality Changed t_{DOH} to 1.3 ns for all speeds Added I-temp offering Changed I_{SB} , I_X values to reflect new char values Added 165 fBGA packaging Added Thermal Resistance values Changed set-up time from 2.0 to 1.5 ns for 167 MHz, 150 MHz and 133 MHz Changed t_{EOHZ} to 4.0 ns for 200 and 167 MHz Changed t_{EOV} to char values Changed t_{CLZ} from 0 to 1.3 ns for all speeds
*A	123131	01/18/2003	RBI	Add power up requirements to operating range information